

Design Information

Images

- Use high-resolution CMYK images. 300 dpi or better
- RGB images will be converted without color matching guarantee / LAB colors are unacceptable.
- Images should not have ICC profiles embedded.
- JPEG should be Hi-Resolution export only

Fonts

- Always convert fonts to outlines or embed all fonts
- Do not allow font substitutions when exporting PDF
- Do not use True Type fonts
- Use BLACK TEXT ONLY for body copy on white backgrounds / 4-color text (especially small point size) is difficult to register on press
- Knockout text (white) against color fills should be of large point size and bold (san-serif preferred) for effective 4-color registration

Colors

- Only use CMYK colors; convert spot colors to CMYK process. RGB images will be converted without color matching guarantee / LAB colors are unacceptable
- Color matching is not guaranteed

Transparency & Fills

- All transparent objects must be flattened at a high resolution.
- Avoid placing transparent objects on top of text or other critical vector objects.
- Minimize color channels used in color fills / Black fills should be ONE-COLOR Black / NOT 4-COLOR Black

Overprint

- Overprinting objects may not reproduce correctly when printed and will sometimes disappear completely. We recommend creating objects exactly as you want them to appear without relying on an overprint setting.

Please Note

- All fonts must be embedded in the PDF - No Truetype.
- All PDFs must be high res/press optimized.
- Color proofs are recommended
- If color is critical, please provide us with a composite SWOP-certified color proof (with color bars) along with your digital file. We cannot grant make goods for poor color reproduction unless a SWOP-certified color proof is supplied with your digital file.
- No proof for client approval will be provided for supplied ads.

If your electronic file does not meet the criteria listed above, BIC Magazine cannot be responsible for the reproduction of your advertisement. No make-good ads or refunds will be given.

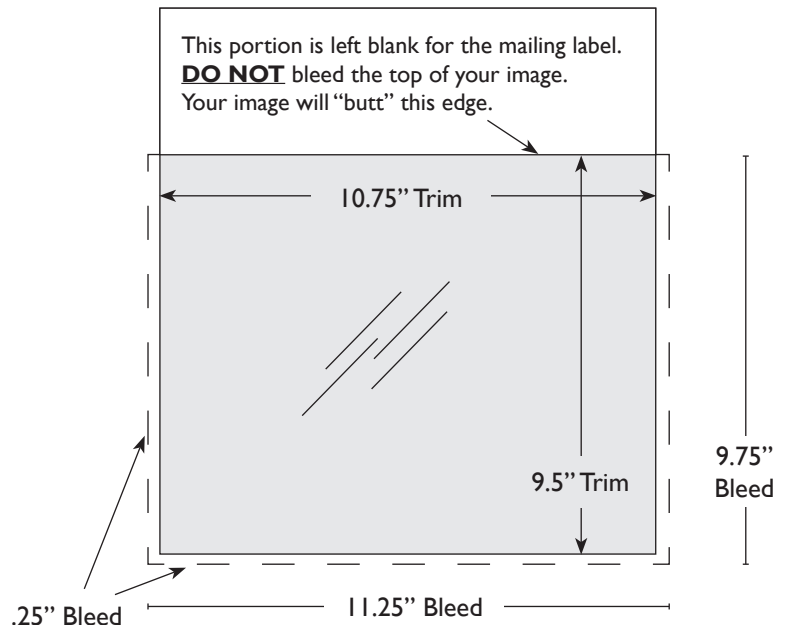

Please see Mechanical Specification sheet for additional information.

Direct questions and send artwork to:

BIC Alliance | Chris Sartell, Creative Production Manager
csartell@bicalliance.com • 281.538.9996